

C8 CORVETTE – Z51/STINGRAY

PERFORMANCE OF VERUS ENGINEERING VENTUS PACKAGES

OVERVIEW

| | |
|---|--------|
| SUMMARY : AERODYNAMIC FORCES | pg. 3 |
| VENTUS 1 PACKAGE | pg. 4 |
| VENTUS 2 PACKAGE (BTM. MOUNT UCW) | pg. 5 |
| VENTUS 2 PACKAGE (SWAN NECK UCW) | pg. 6 |
| VENTUS 3 PACKAGE | pg. 7 |
| VENTUS 4 PACKAGE | pg. 8 |
| DIVE PLANES / CANARDS | pg. 9 |
| DIFFUSER (ALUMINUM) | pg. 10 |
| DIFFUSER (CARBON) | pg. 11 |
| SPLITTER | pg. 12 |
| HIGH DOWNFORCE SPLITTER | pg. 13 |
| SIDE SPLITTERS | pg. 14 |
| UCW REAR WING (BTM. MOUNT) | pg. 15 |
| UCW REAR WING (SWAN NECK) | pg. 16 |
| WCW REAR WING | pg. 17 |
| V1X REAR WING | pg. 18 |
| SUMMARY : UCW & V1X REAR WINGS | pg. 19 |
| DUCKTAIL SPOILER | pg. 20 |
| BRAKE DUCT BLOCK-OFF | pg. 21 |
| CONTROL ARM GUIDE STRAKES | pg. 22 |
| SUMMARY | pg. 23 |
| QUALITY OF CAD MODEL | pg. 24 |
| THE SCIENCE | pg. 25 |
| DEFINITIONS | pg. 26 |

SUMMARY : AERODYNAMIC FORCES

- Aerodynamic forces change with the square of the vehicle speed, which is why we use a graph.
- The Ventus packages significantly increase downforce over stock with a comparatively minimal impact to drag and are a great choice for track enthusiasts and competitive racers alike.
- The Ventus 1 package uses the Verus Engineering Dive Planes and your choice of Aluminum Rear Diffuser with Polyweave Spats, or our Carbon Diffuser. The Carbon Diffuser produces slightly more downforce than the Aluminum Diffuser. This is illustrated by the diverging grey lines on the graph to the right.
- The Ventus 2 packages add the Front Splitter, Side Splitters, Ducktail Spoiler & Bottom Mount or Swan Neck UCW. Either the Aluminum or Carbon Air Dam can be selected.
- The Ventus 3 package adds the Front Splitter End Plates and WCW Rear Wing.
- The Ventus 4 package moves to our High Downforce Front Splitter, corresponding End Plates and V1X Rear Wing.
- Angle of Attack (AoA) adjustment allows the driver to fine tune aerodynamic balance to his or her preference.
- The thick diverging lines for Ventus 1, 2, & 3 show performance/balance variations depending on setup.
 - Ventus 2 is shown from 0° AoA to 12° AoA with the UCW
 - Ventus 3 is shown from 0° AoA to 12° AoA with the WCW
 - Ventus 4 is shown from 1.9° AoA to 10° AoA with the V1X
 - At 12° the Ventus 3 package with WCW produces 8% more downforce than the Ventus 2 package with Swan Neck UCW with the same drag.
 - The V1X at 1.9° produces 2% more downforce than the UCW at 12° with 5% less drag.

Verus Engineering Ventus Packages

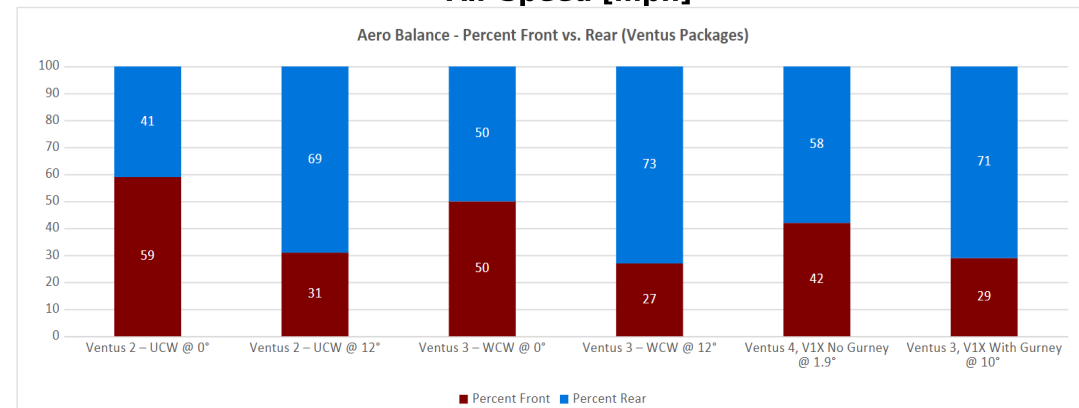
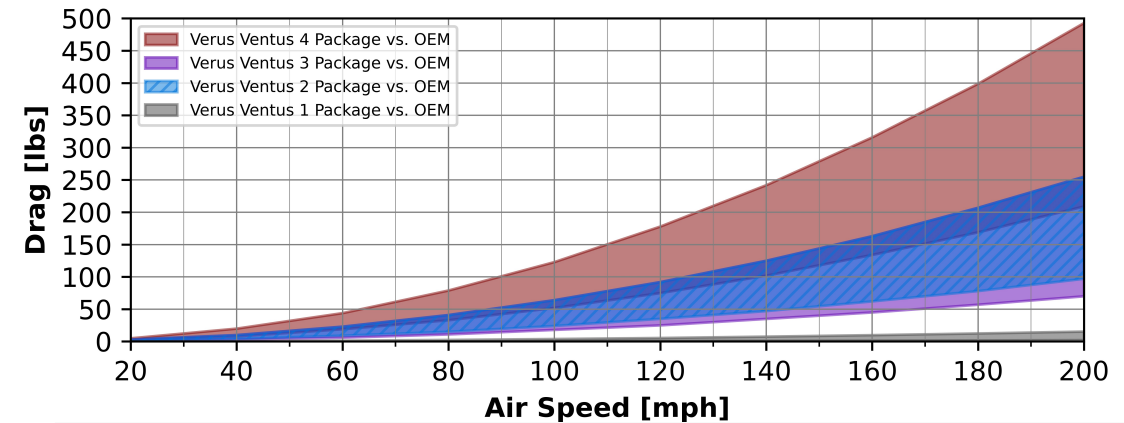
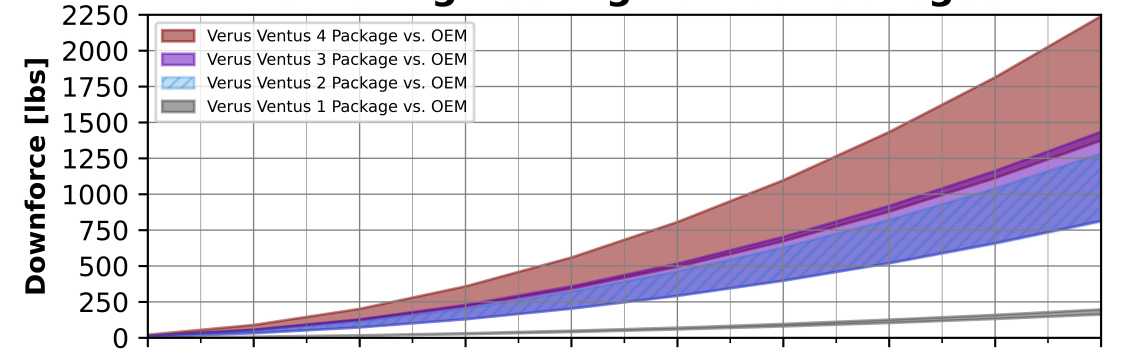

VENTUS 1 PACKAGE

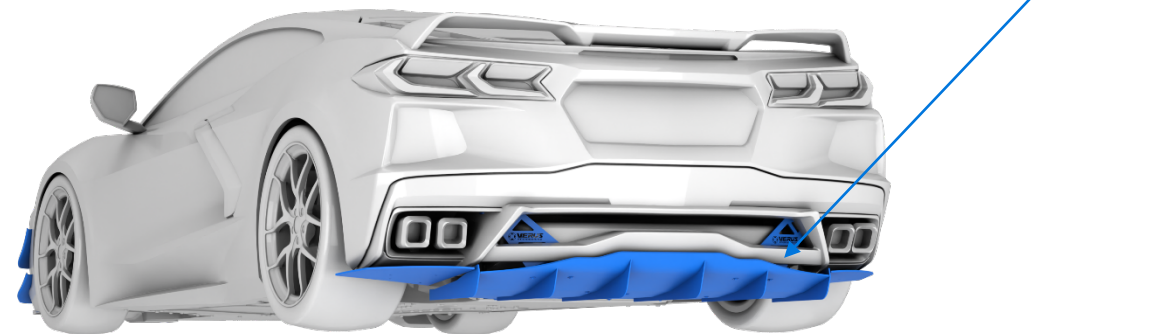
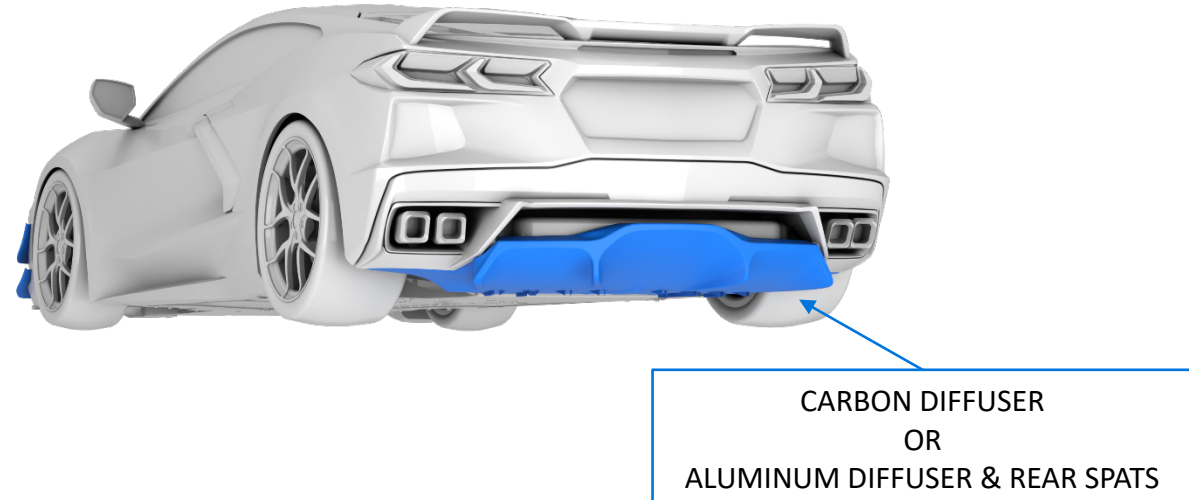
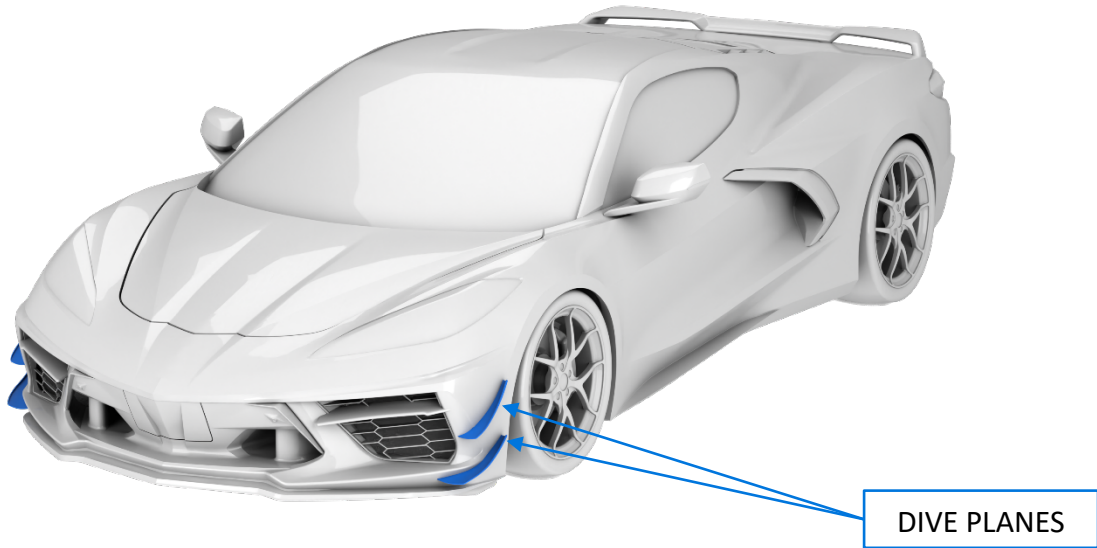

VENTUS 2 PACKAGE (BTM. MOUNT)

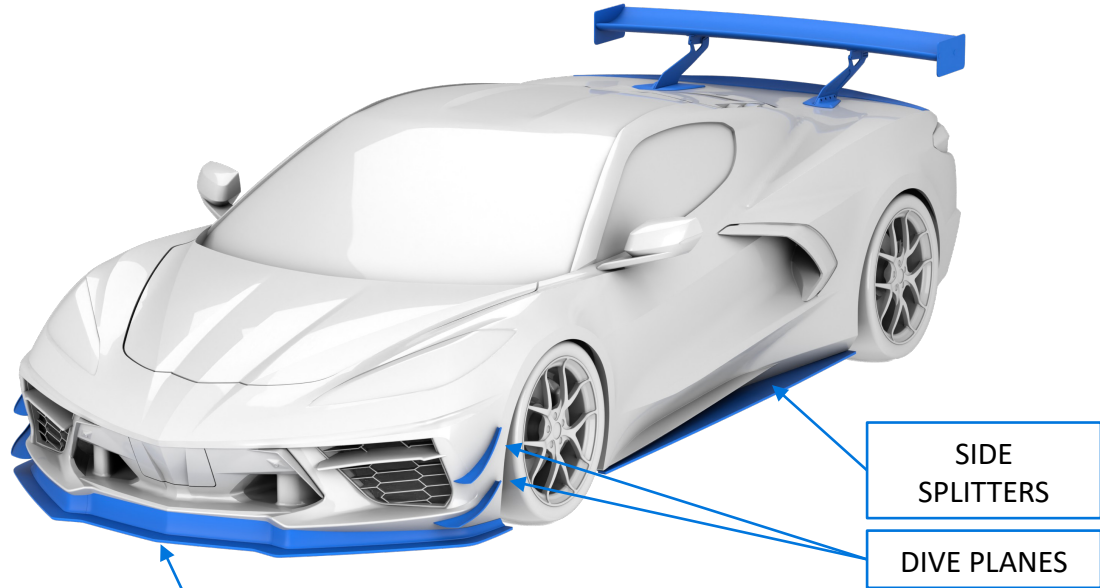

SPLITTER & CARBON AIR DAM
OR
SPLITTER & ALUMINUM AIR DAM



CARBON DUCKTAIL

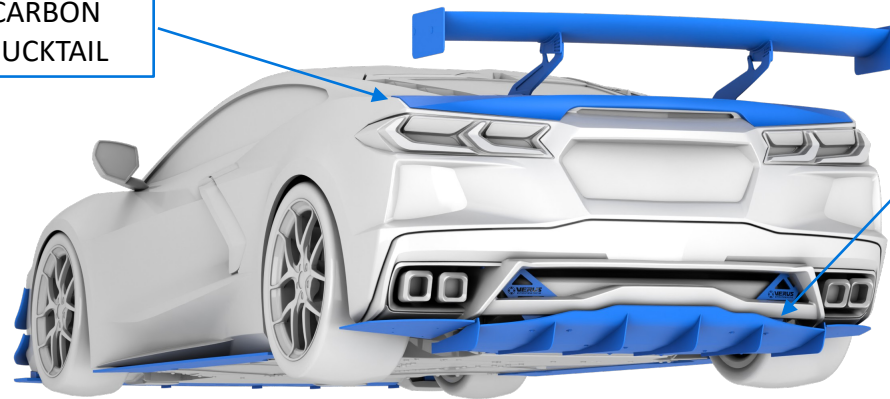

VENTUS 2 PACKAGE (SWAN NECK)

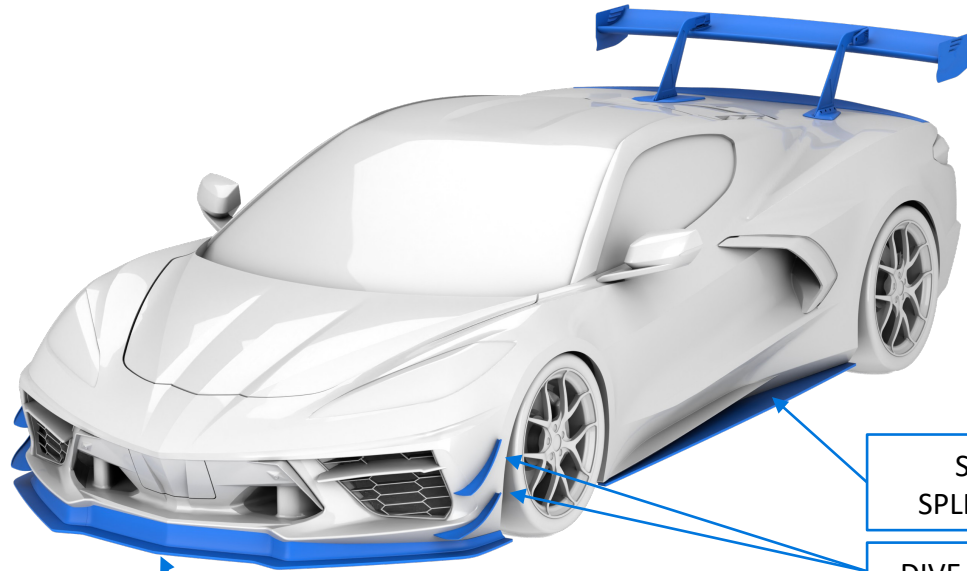

SIDE
SPLITTERS

DIVE PLANES

SPLITTER & CARBON AIR DAM
OR
SPLITTER & ALUMINUM AIR DAM



UCW
REAR WING

CARBON DIFFUSER
OR
ALUMINUM DIFFUSER & REAR SPATS

CARBON
DUCKTAIL



VENTUS 3 PACKAGE (WCW WING)

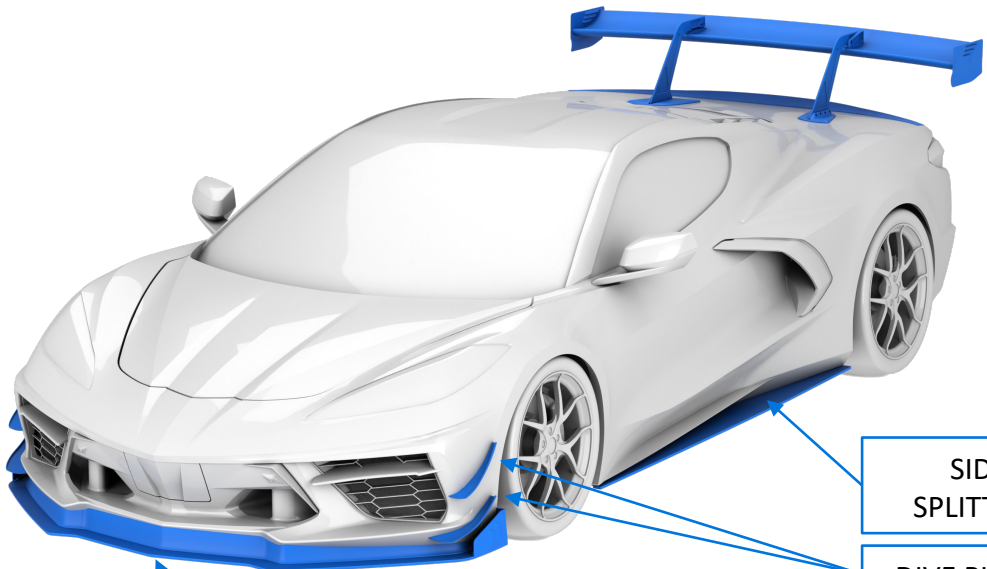

SIDE
SPLITTERS
DIVE PLANES

SPLITTER & CARBON AIR DAM
OR
SPLITTER & ALUMINUM AIR DAM



SPLITTER END PLATES



WCW
REAR WING

CARBON DIFFUSER
OR
ALUMINUM DIFFUSER & REAR SPATS

CARBON
DUCKTAIL



VENTUS 4 PACKAGE (V1X WING)

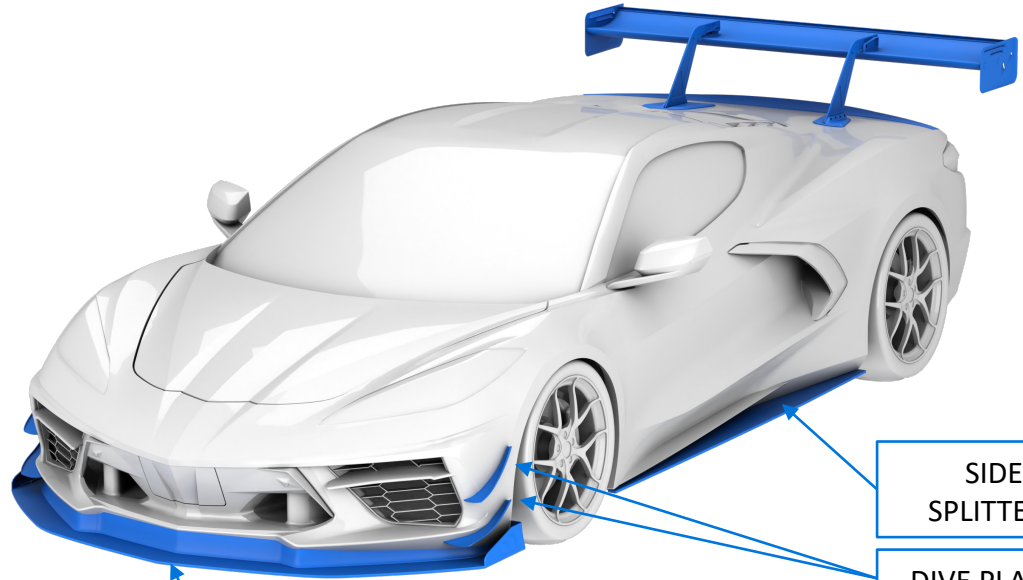

SIDE
SPLITTERS

DIVE PLANES

HD SPLITTER & CARBON AIR DAM
OR
HD SPLITTER & ALUMINUM AIR DAM



HD SPLITTER END PLATES



V1X
REAR WING

CARBON DIFFUSER
OR
ALUMINUM DIFFUSER & REAR SPATS

CARBON
DUCKTAIL



DIVE PLANE / CANARDS

- Dive planes are great for customers looking for a slight bump in front downforce and no reduction in ground clearance.
- Verus Engineering develops dive planes to produce downforce by controlling the flow around the vehicle, not on the units themselves, improving efficacy.
- A small amount of downforce is produced on the units themselves, high pressure on top, low pressure on bottom.
- We develop the dive planes to create a beneficial vortex which helps evacuate the fenders.
- This evacuation reduces lift on the body, improving performance.
- The dive planes are produced from 2x2 twill carbon fiber finished in an automotive clear coat. Templates are supplied to ensure location of the units are correct.

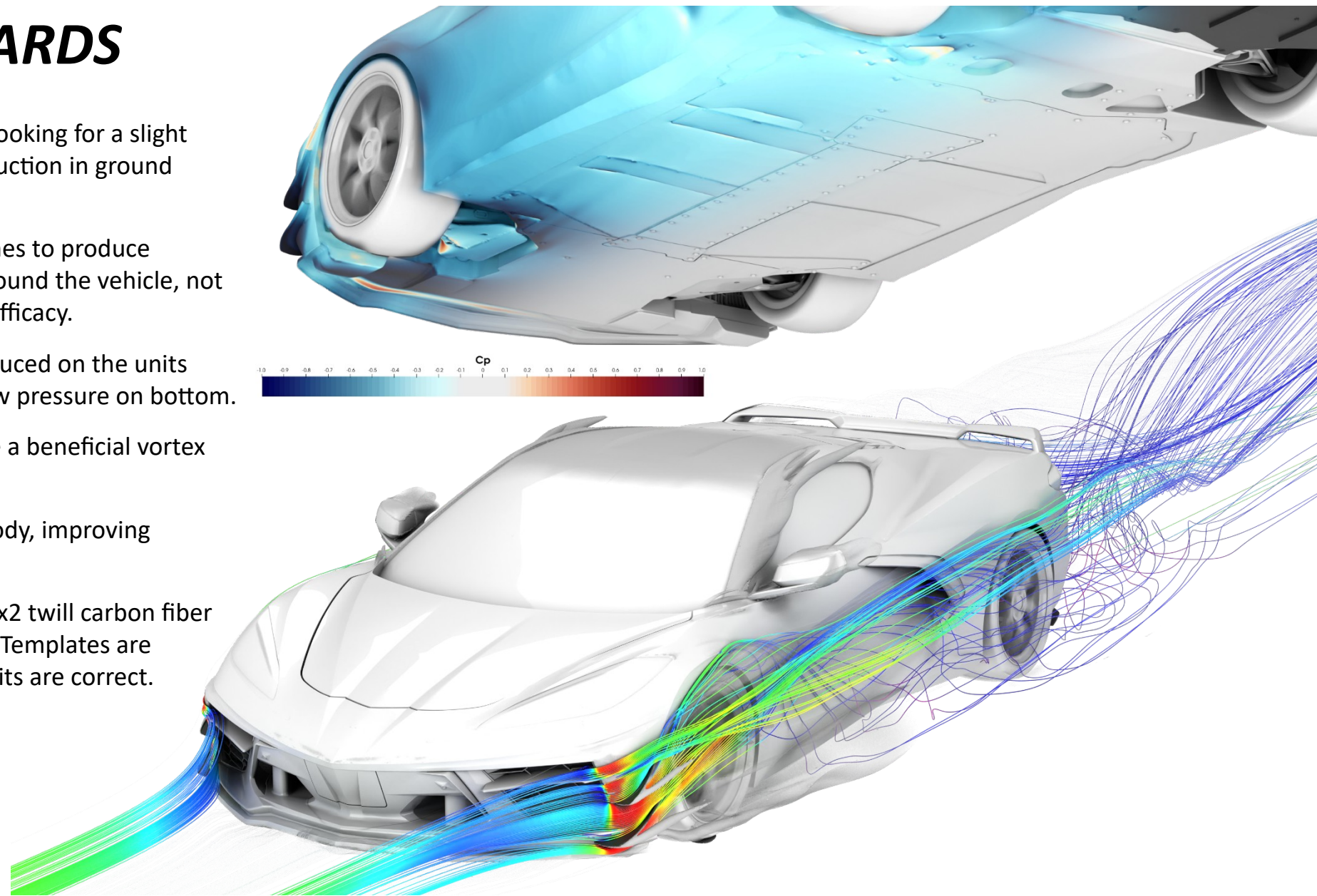

DIFFUSER (ALUMINUM)

- The rear diffuser is a key component in creating efficient downforce.
- A diffuser is perfect for a street car as it will add stability (downforce) *and* reduce overall drag, when designed properly.
- The diffuser functions by creating low pressure on the bottom surface and reduces drag by filling in the wake region behind the vehicle.
- A large portion of drag on road vehicles is pressure drag, which is the low pressure region behind the car.
- This low pressure region (aka wake region) creates a force that pulls rearward on the car.
- Using CFD and good design practices, we developed a solution that creates downforce and reduces drag.
- This rear diffuser is constructed from sheet aluminum. It attaches to various chassis and bumper locations to ensure for a secure, durable, and low cost unit.

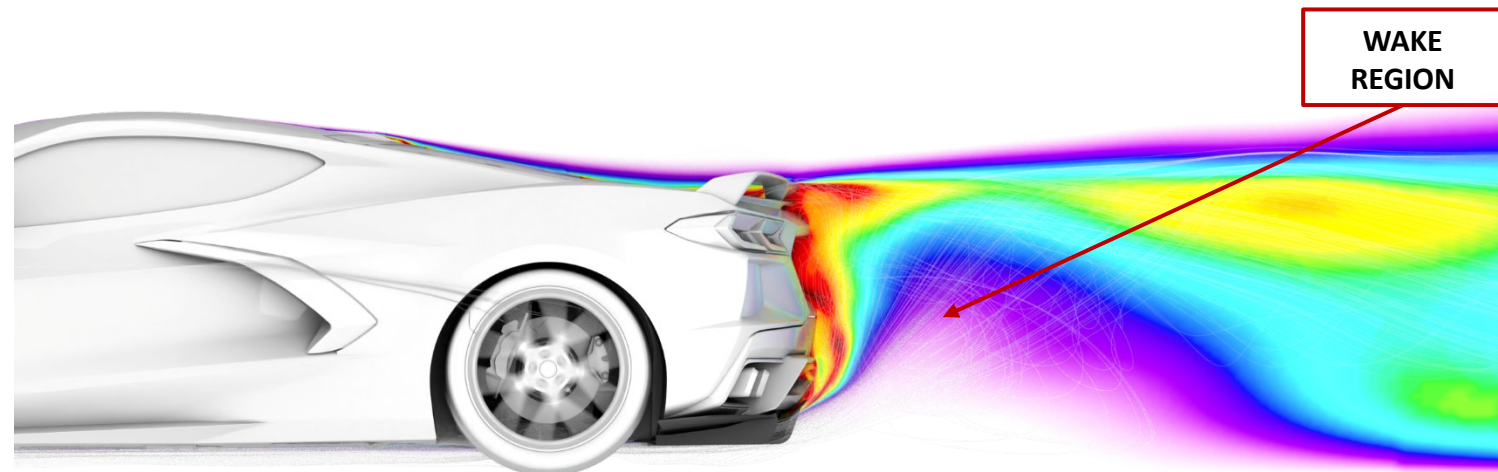
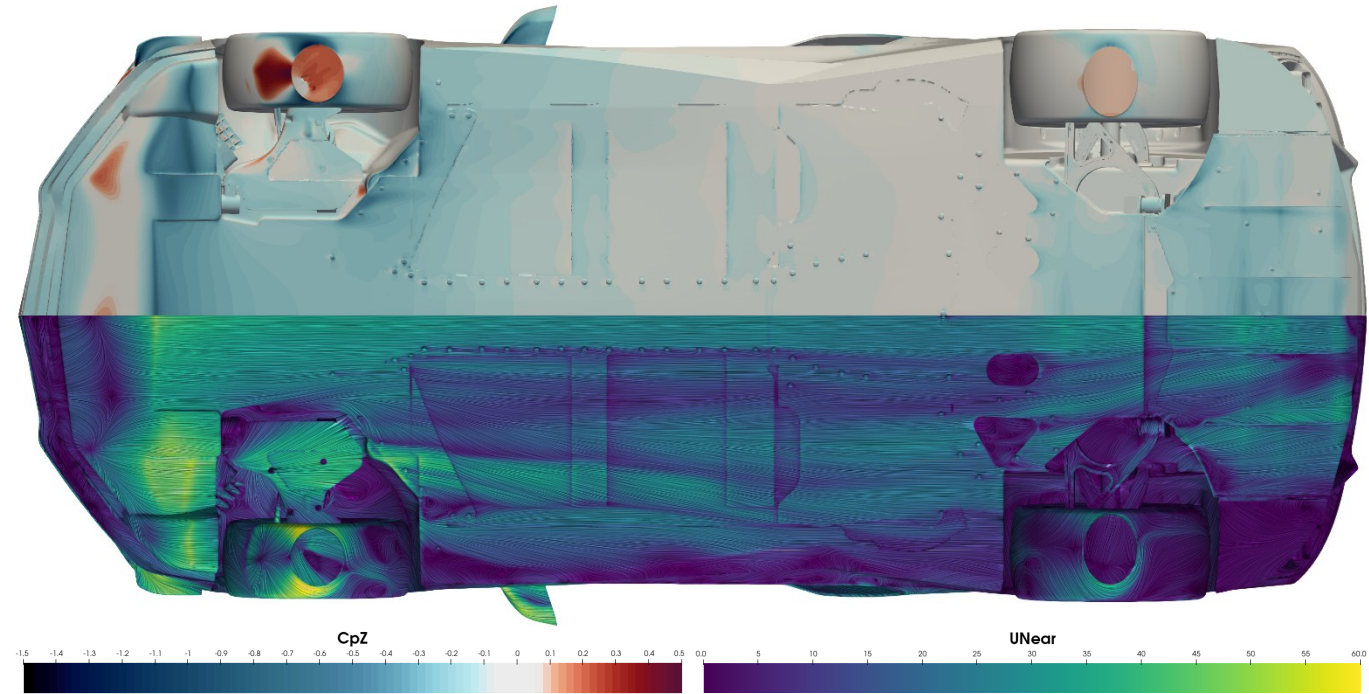

DIFFUSER (CARBON)

- The carbon diffuser was developed with a similar methodology as the aluminum one.
- The design freedom afforded by working with carbon allowed us to create more downforce than was possible with the aluminum diffuser.
- The carbon diffuser also makes for a more exotic look that matches the 'Stingray' design language.
- Compare the CpZ plots to the right. When paired with our Ventus 3 package the blue areas (downforce) on the floor and diffuser are much larger and darker in color. This illustrates how our splitter and rear wing can work together with the diffuser. The same applies to the aluminum diffuser, with slightly lower peak performance.

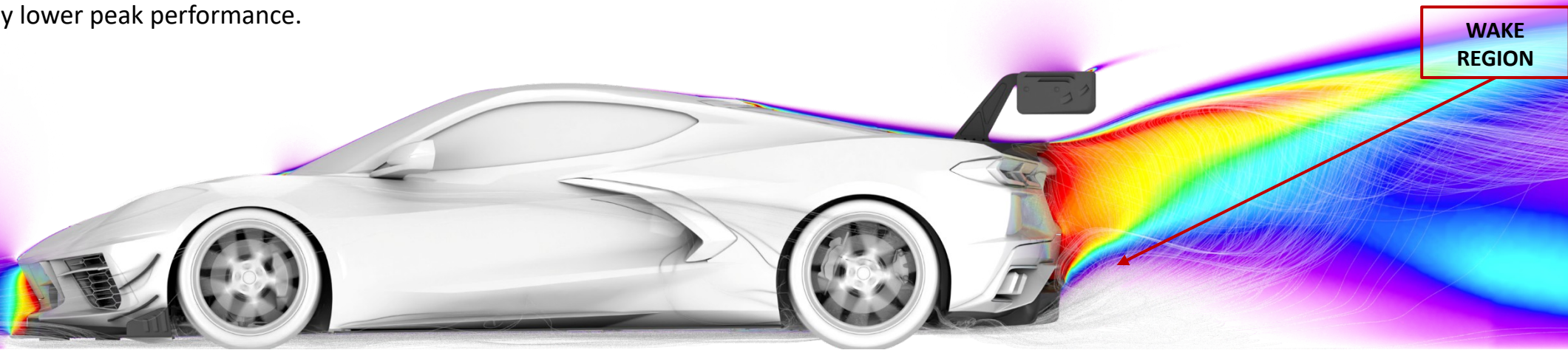
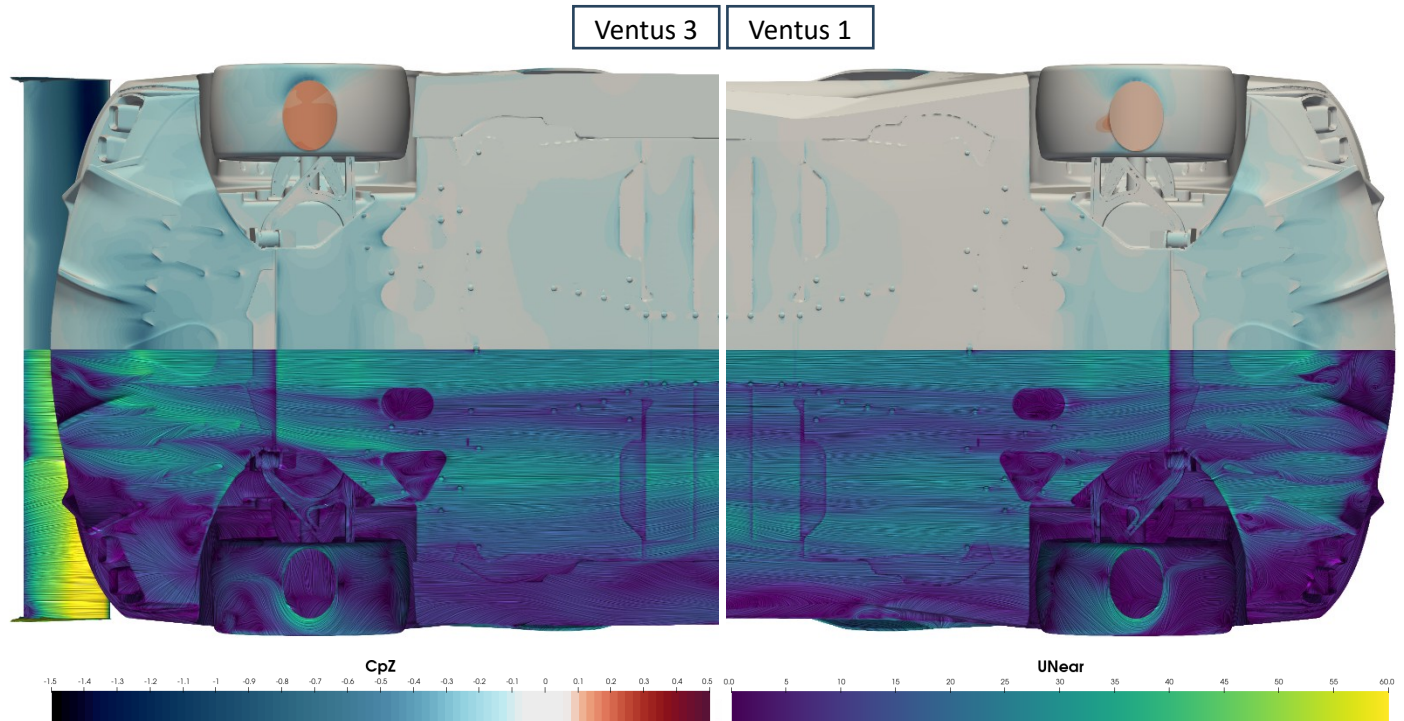

SPLITTER

- The splitter is great for customers looking to generate significantly more front end downforce.
- The entire splitter assembly is modeled and simulated. Including front heat exchangers exiting in the wheel well.
- Front splitters are very efficient aero devices.
- High pressure on the top side helps drive the splitter downward at speed.
- The bottom side, like the rear wing, produces more downforce than the top side.
- The Verus Engineering splitter includes surfaced sections to feed the factory diffusers for improved performance.
- Optional End Plates provide an additional bump in downforce. They also significantly shift aero balance forward. This allows the use of more wing angle, or the addition of the V1X rear wing.
- Our splitter is a motorsports grade composite material. Carbon Polyweave is rigid while exhibiting excellent wear characteristics. Where traditional carbon fiber components may fail due to an impact, the Carbon Polyweave will not.

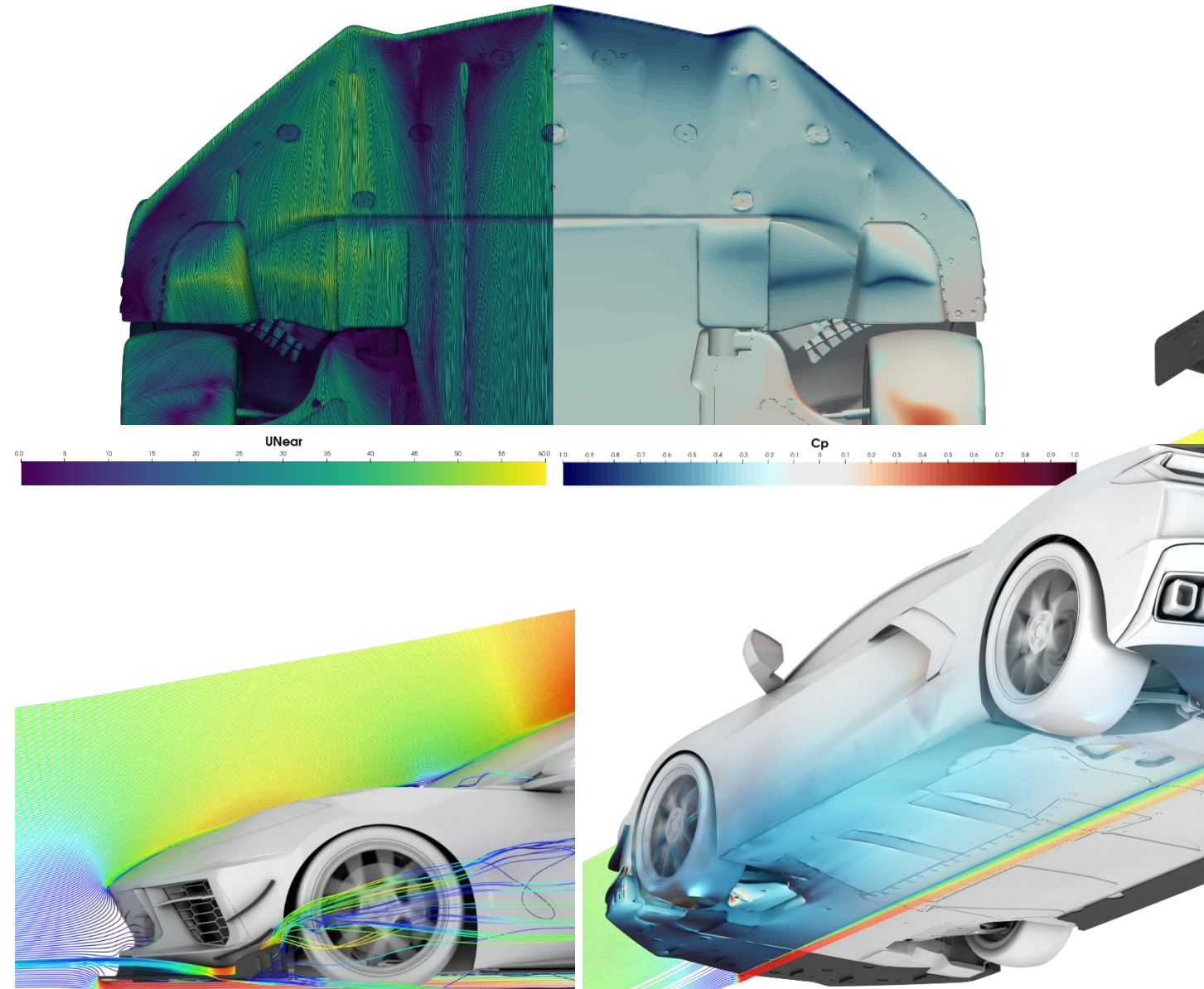

HIGH DOWNFORCE SPLITTER

- The high downforce splitter adds significant front end downforce to the C8 with a minimal increase in front overhang.
- Changing from the standard splitter to hd splitter alone results in 8.6% more total downforce for only 2.9% more drag. However this results in the aero balance shifting from 27% front, to 39% front (WCW @ 12°). When switching to the V1X and adjusting to match the 27% front balance, total downforce increases by 40% with only 19% more drag.
- The entire splitter assembly is modeled and simulated. Including front heat exchangers exiting in the wheel well.
- This splitter retains most of the features of the standard splitter while adding or changing the following:
 - Adds 3D printed fiber reinforced ABS diffuser tunnels
 - Replaces entire factory plastic under-tray
 - Optional, larger 3D printed end plates

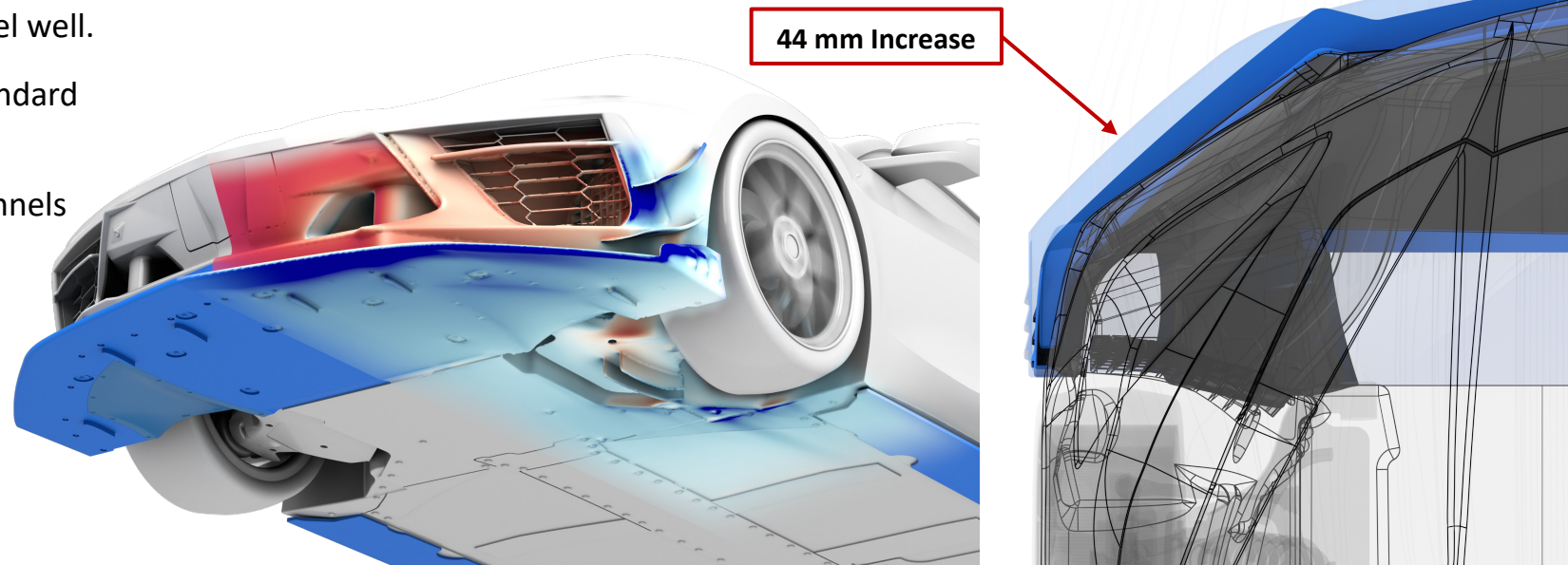
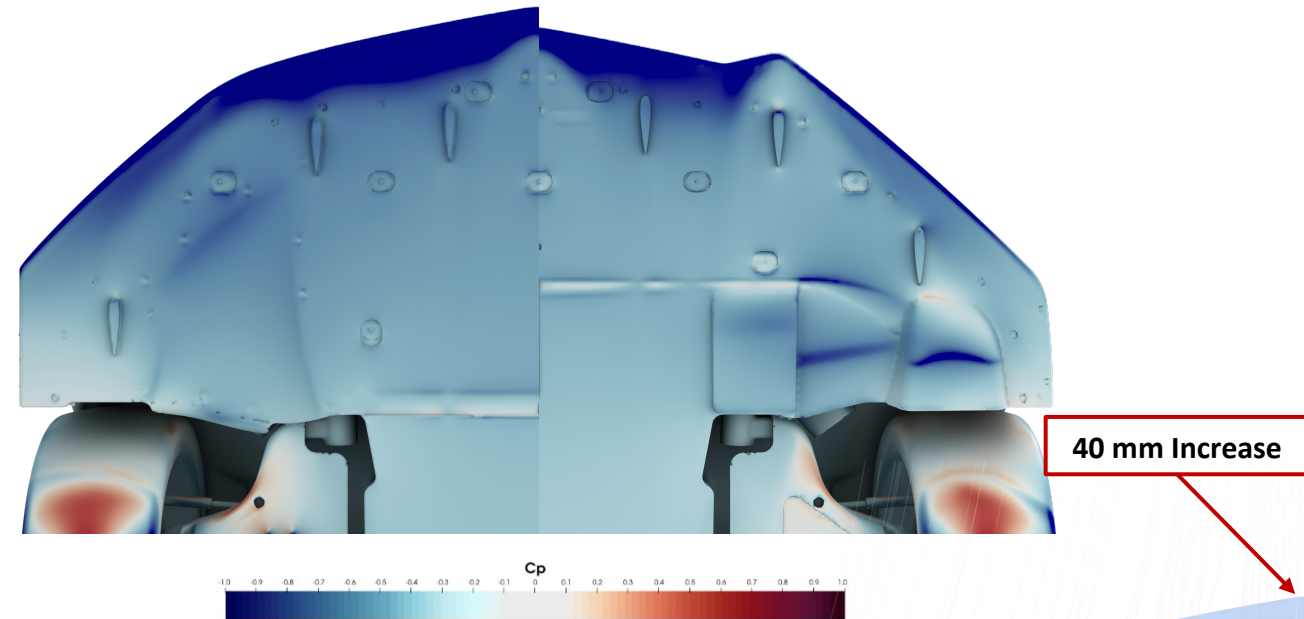

SIDE SPLITTERS

- Side splitters reduce the amount of high pressure air from the top side of the vehicle making it under the vehicle.
- We focused on designing the units to clean up underbody airflow during turning or high yaw conditions.
- The increase in downforce is centrally located on the vehicle and the aero balance is minimally affected.
- Our side splitters are made with a motorsports grade composite material. Carbon polyweave is rigid while exhibiting excellent wear characteristics. Where traditional carbon fiber components may fail due to an impact, the carbon polyweave will not.
- The side splitters bolt to the vehicle using supplied hardware installed in the factory side skirt locations.

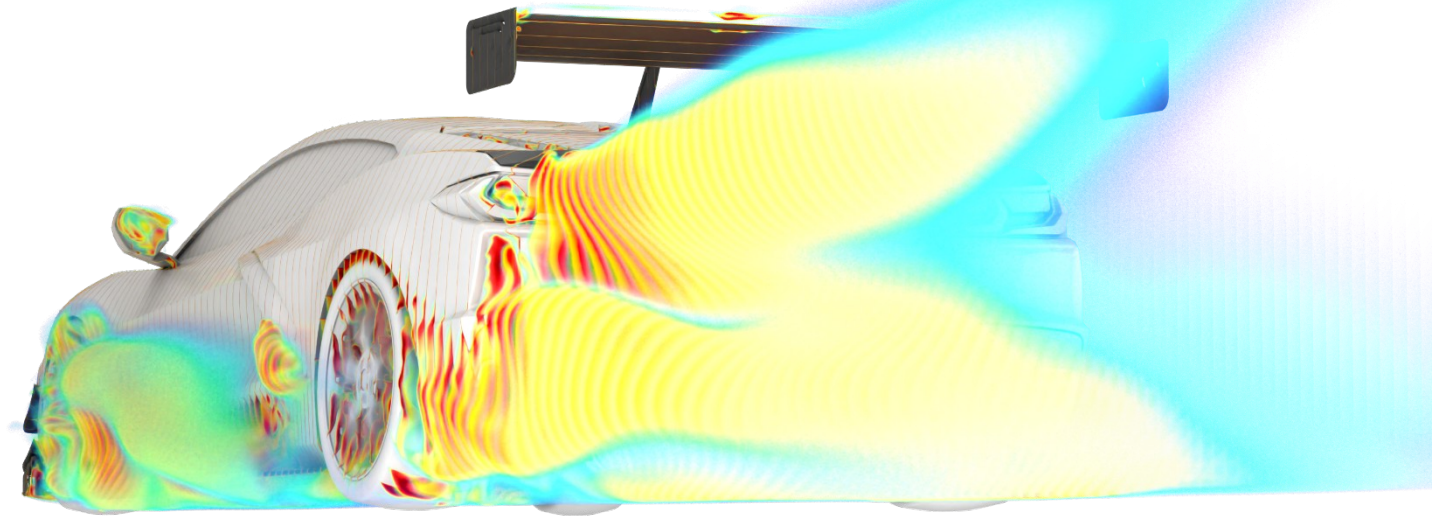
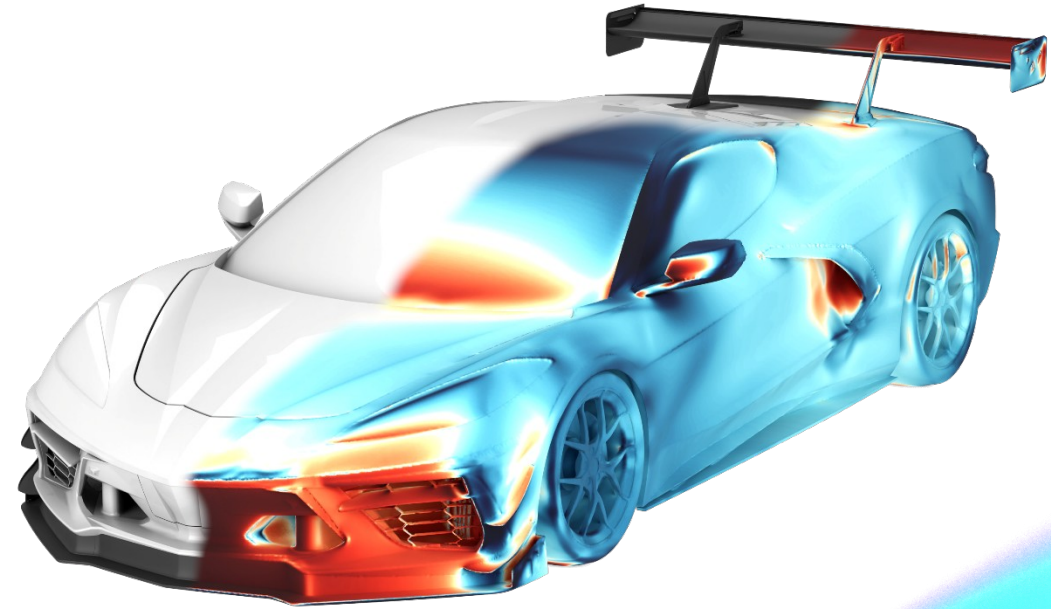

UCW REAR WING (BTM. MOUNT)

- This rear wing is great for customers looking for a large bump in rear downforce.
- The UCW wing profile was developed in CFD and refined in the wind tunnel.
- The airfoil produces substantial downforce on the C8 Z51/Stingray.
- The bottom surface is where the majority of the downforce is generated. This low pressure pulls the car downward.
- The top surface still produces downforce, but not like the bottom surface.
- The mounts are machined from 6061 aluminum and have a lower surface matched to the contour of the OEM engine cover. They sandwich the engine cover using a large surface area lower mount. This makes for a mounting kit strong enough for our higher performance V1X element.
- The UCW is produced from 2x2 twill carbon fiber finished in an automotive clear coat.

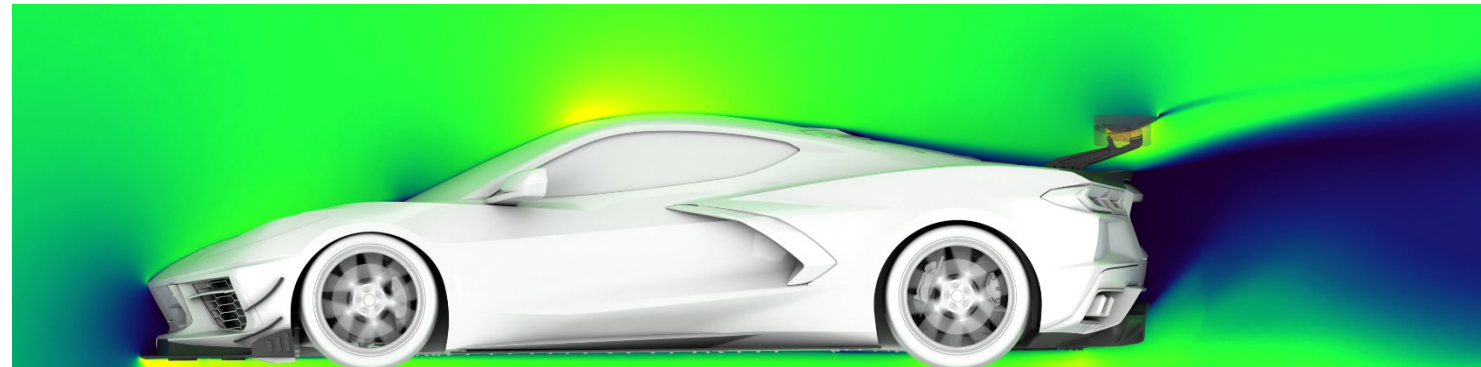

UCW REAR WING (SWAN NECK)

- This rear wing offers a slight performance improvement over the bottom mount UCW. Total downforce and L/D are improved.
- This wing uses the same CFD developed and wind tunnel refined wing element as the bottom mount wing.
- The bottom surface is where the majority of the downforce is generated. This low pressure pulls the car downward.
- The top surface still produces downforce, but not like the bottom surface.
- Switching to a swan neck mount has less impact on the bottom surface of the wing element. However, our wings position the uprights in-line with the engine cover vents since it is already a location of disrupted airflow. The impact of the engine bay flow means that the performance improvement from switching from bottom mount to swan neck isn't as large as it may be for other platforms. In this case, choose the one that looks the best to you!
- The swan neck UCW is fixed to the vehicle using the exact same components as the bottom mount UCW, making for a streamlined path to altering the look of your C8. The UCW is produced from 2x2 twill carbon fiber finished in an automotive clear coat.

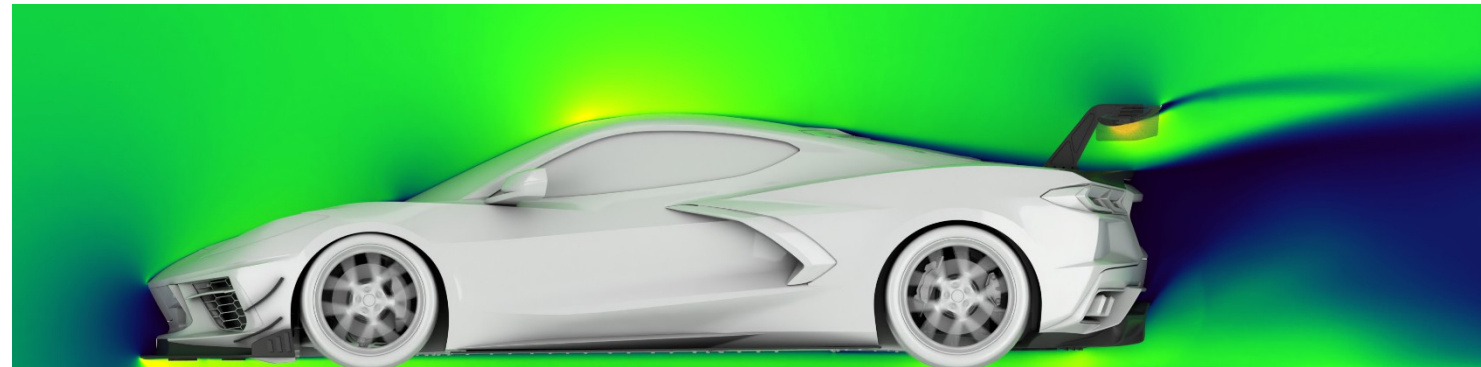
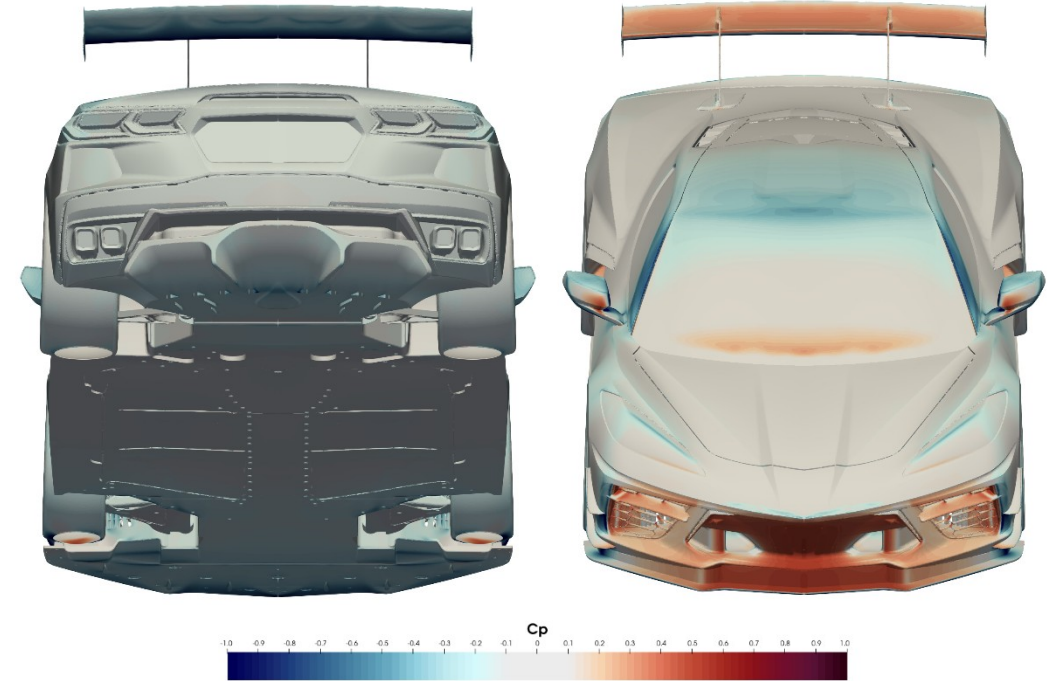

WCW REAR WING

The chord and curvature of the WCW is an exact match to the UCW with increased span. This has been achieved by offsetting the endcaps from a total span of 1600 mm to 1785 mm.

The WCW was designed with a few factors in mind:

- By increasing the span while keeping the chord fixed, the WCW is a higher aspect ratio ($AR = \text{span}/\text{chord}$) element than the UCW.
- The increased AR results in greater downforce, driven primarily by the larger planform area.
- On the C8, the WCW is more efficient than the UCW (see downforce vs drag comparison below).
- The WCW offers an alternate look. The increased span may be seen as an improved aesthetic match for wide cars like the C8.

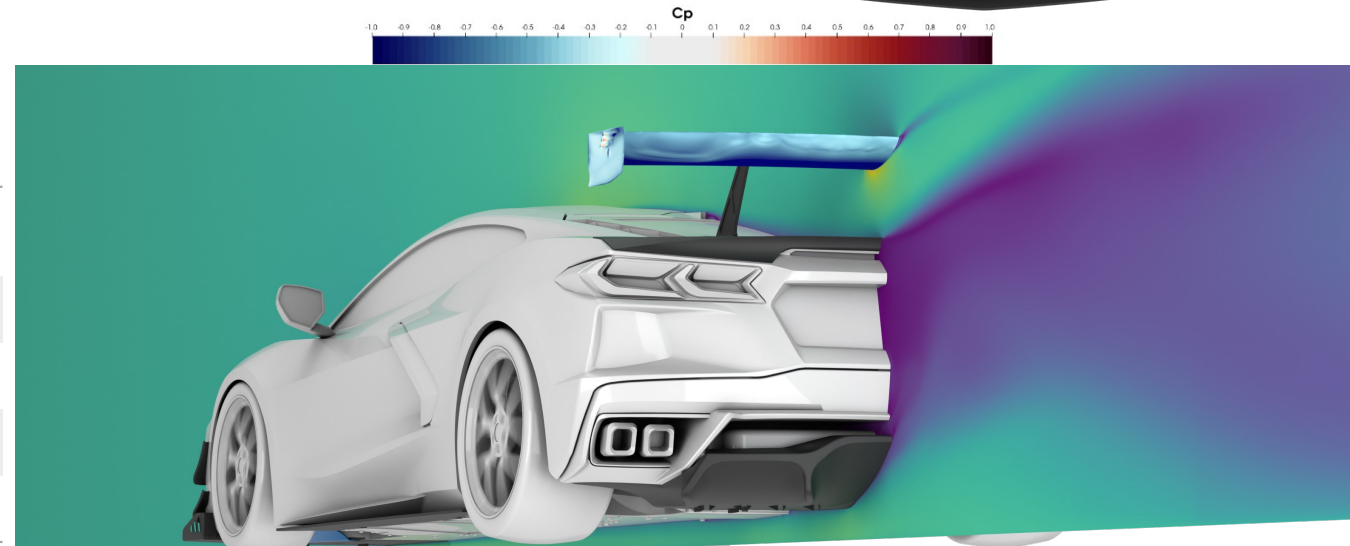

| | Ventus 2 UCW @ 12°AOA | Ventus 2 WCW @ 12° AOA | Percent Difference |
|---------------------------|--------------------------|---------------------------|-----------------------|
| Span (mm) | 1600 | 1785 | + 11.6% |
| Downforce (lbs) @ 120 mph | 672 | 728 | + 8.3% |
| Drag (lbs) @ 120 mph | 452 | 452 | 0.0% |
| Balance (% Front/Rear) | 31.0/ 69.0 | 27.2 / 72.8 | 12.3% |

V1X REAR WING

The same methodology as the UCW but with capacity for much higher downforce (see charts on the following page).

The V1X was designed with efficiency in mind:

- The airfoil shape was optimized using adjoint and optimization methods in CFD and correlated in the wind tunnel.
- Slots on the endplate decrease vortex energy off the endplate. Decreasing vortex energy reduces pressure drag.
- Swan Neck mount provides the V1X with cleaner air and more bottom surface area to make more efficient downforce.
- 1850mm is the default wing width for the C8. However, you can custom order the width you want up to 1950mm.

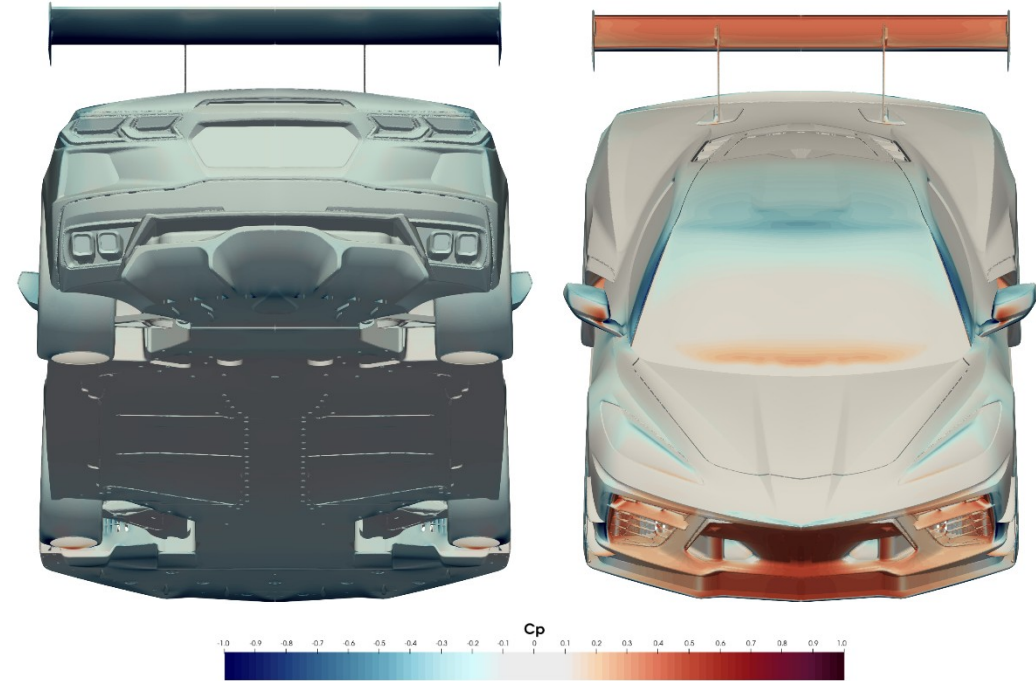

| | Ventus 2 UCW @ 12°AOA | Ventus 3 V1X @ 1.9° AOA | Percent Difference |
|---------------------------|--------------------------|----------------------------|-----------------------|
| Chord (mm) | 250 | 300 | + 20% |
| Downforce (lbs) @ 120 mph | 660 | 674 | + 2.1% |
| Drag (lbs) @ 120 mph | 448 | 426 | - 4.9% |
| Balance (% Front/Rear) | 32.2/ 67.8 | 37.3 / 62.7 | + 15.8% |

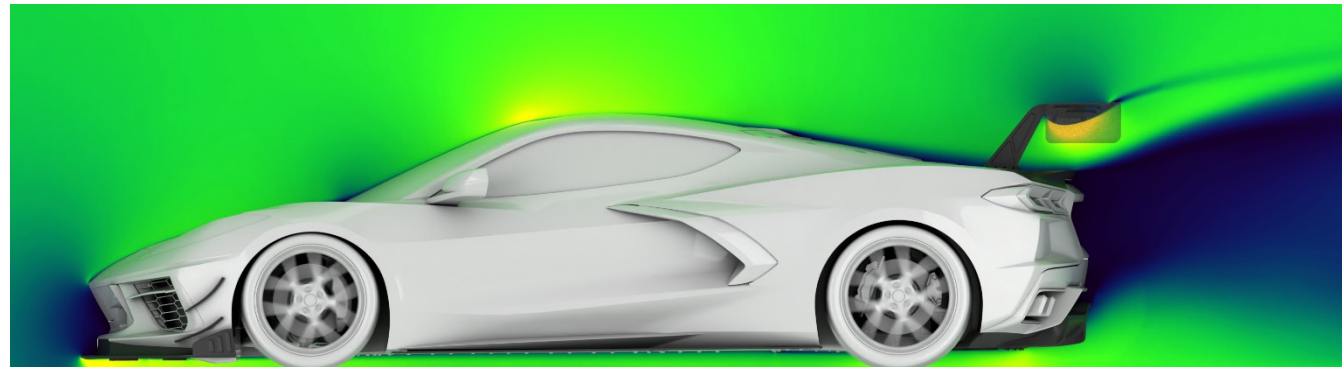

SUMMARY : UCW & V1X REAR WINGS

Verus Engineering UCW Wing

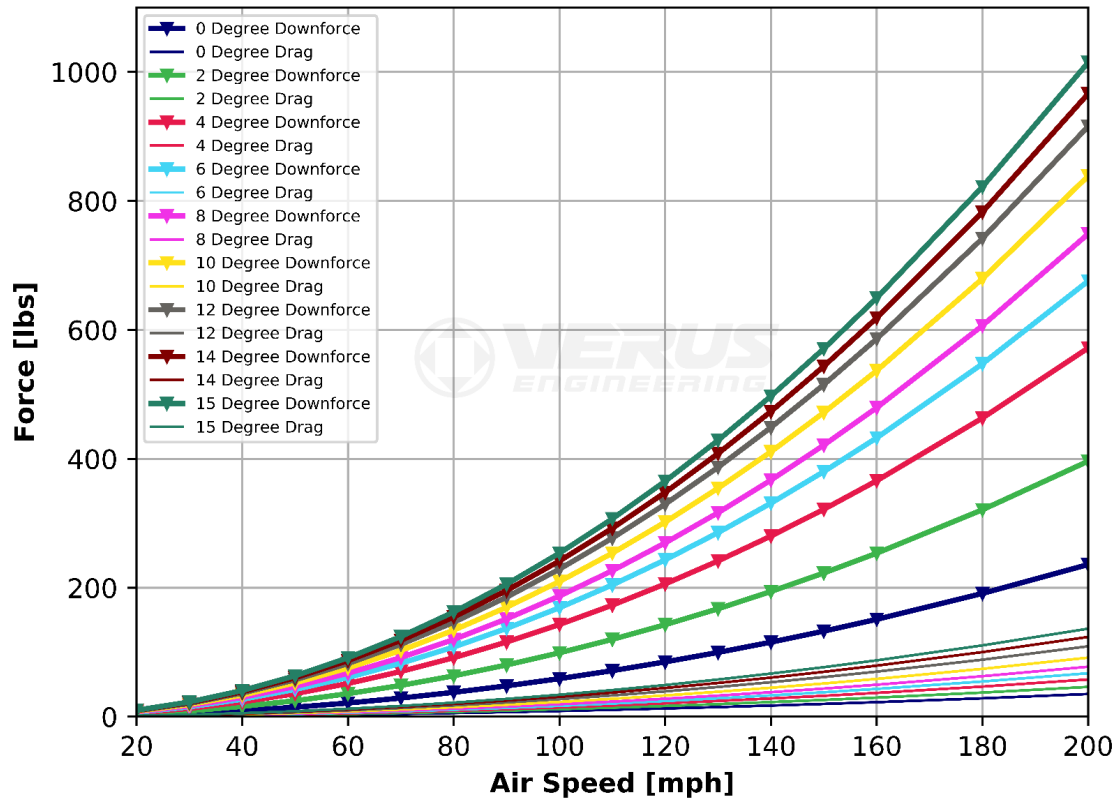

Verus Engineering V1X Wing

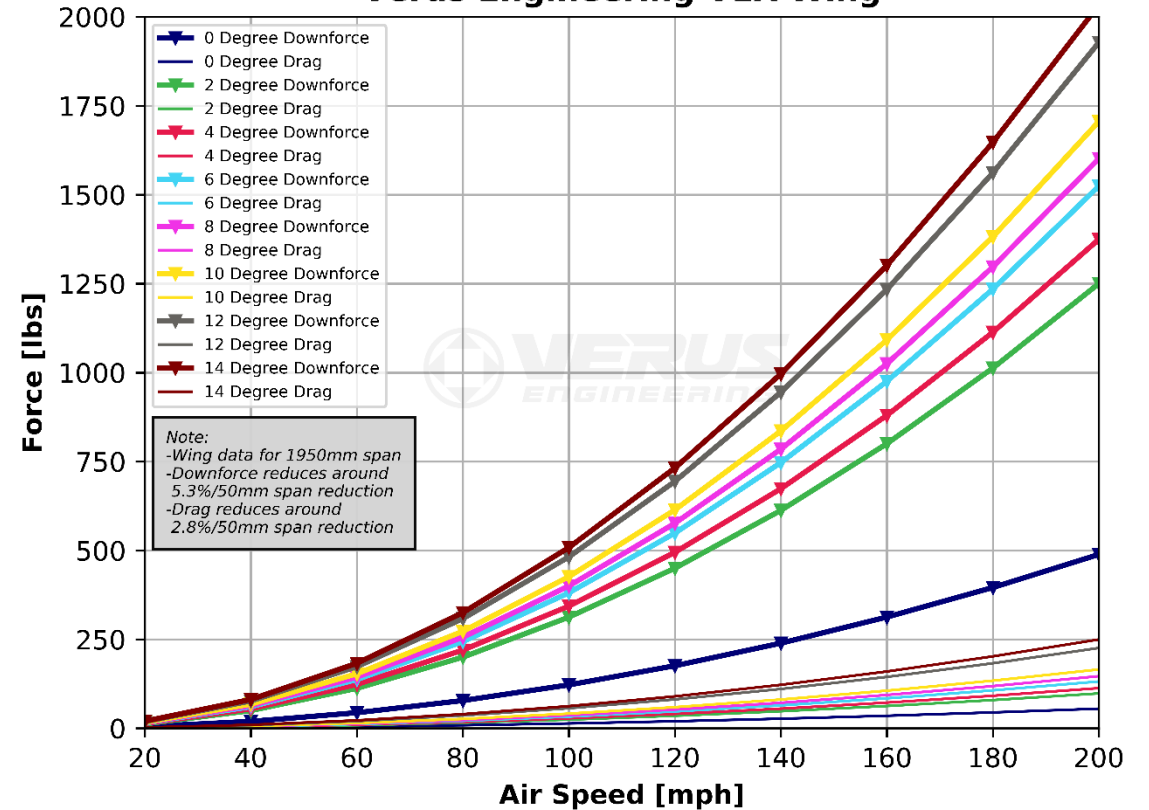

DUCKTAIL SPOILER

- Much like the dive planes, Verus Engineering developed the ducktail spoiler produce downforce by controlling the flow around the vehicle, not on the spoiler itself.
- Removing the ducktail spoiler from a Ventus 3 equipped C8 reduces total vehicle downforce by 10.6%
- The ducktail spoiler also provides an aesthetically pleasing way to cover the holes in the rear bumper when removing a factory installed spoiler/wing.
- The ducktail spoiler was designed to follow and accentuate the factory body lines, adding a hint of aggression.

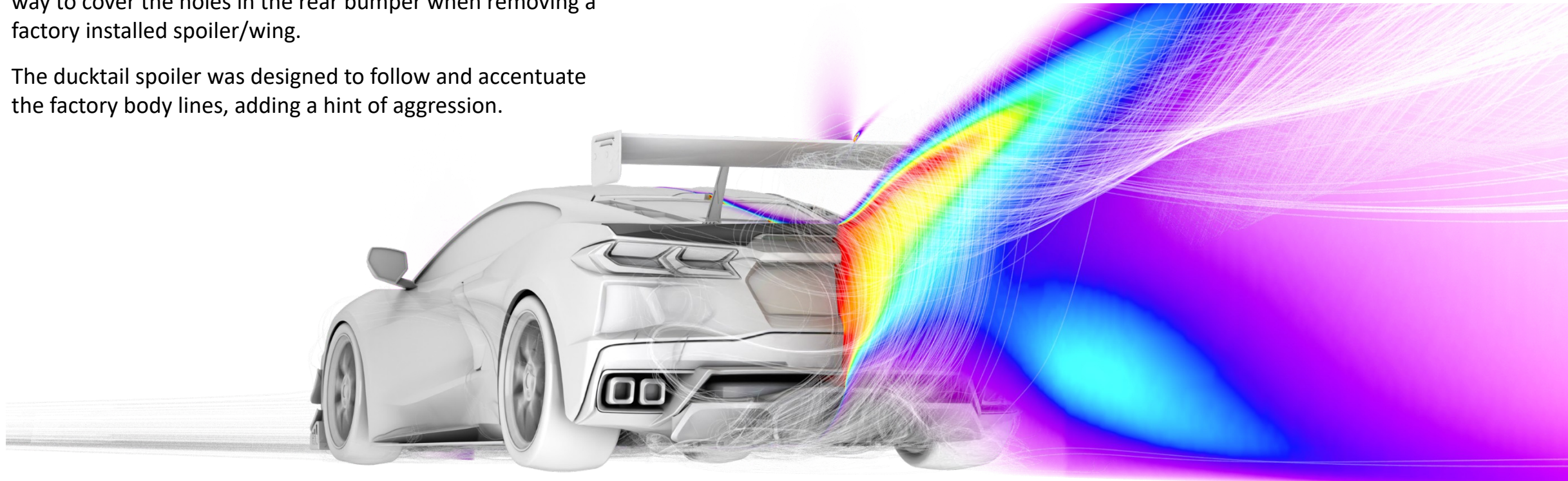
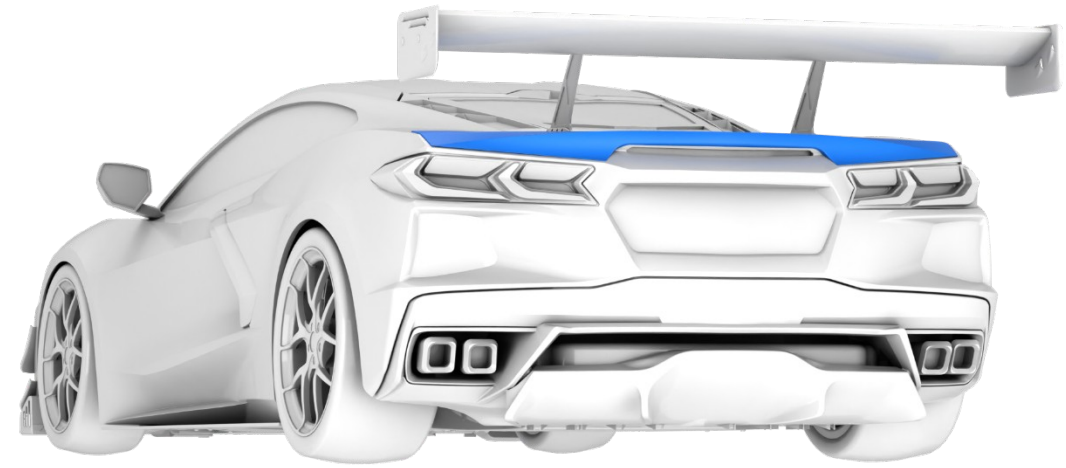

BRAKE DUCT BLOCK-OFF

- The C8 comes with really good brake cooling compared to what is typically seen on a factory street car.
- In some situations the cooling provided by this ducting may be excessive.
- This has mainly been seen on track cars with big brake kits. The extra size, thermal capacity, as well as aggressive track-use brake compounds.
- Adding the brake duct block-off increased total downforce by 4% and reduced total drag by 0.8%. Front balance changed from 18% to 23%. This test was done on the Ventus 3 package, with carbon diffuser and a 10° wing angle.
- The Cp plot in the bottom right shows the difference between Cp with the block-offs and without them. Red areas are areas where pressure is higher with the brake duct than without. Blue areas are of lower pressure with the duct than without.
- The block-offs can serve as an aerodynamic balance tuning device, just ensure you are confident in your braking performance and proceed with caution when removing cooling capacity.

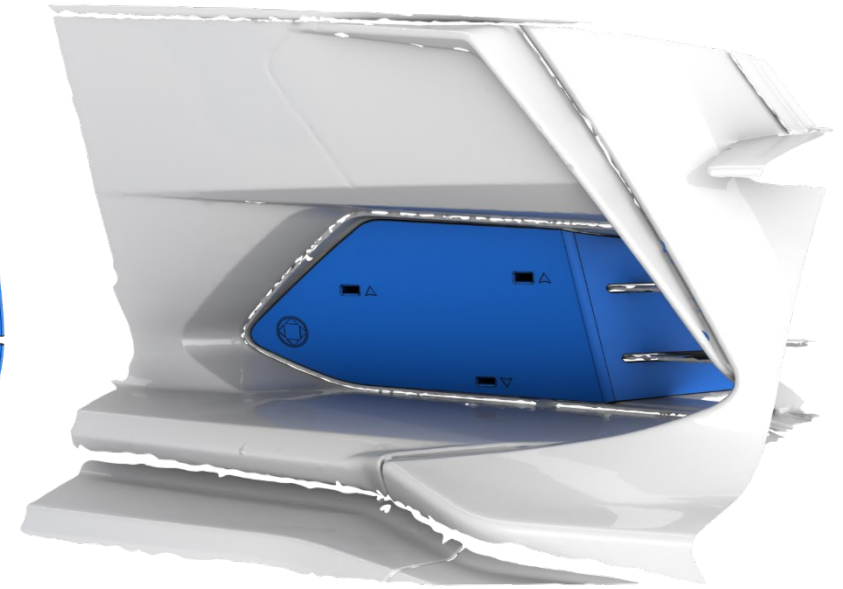
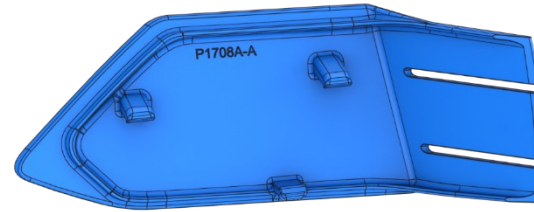

CONTROL ARM GUIDE STRAKE

- The control arm guide strakes increase the downforce generated by the C8 body.
- Most of the additional downforce is created by modifying the airflow around the body rather than producing downforce with the surfaces of the part. This is more similar to the function of our dive planes than a wing element.
- The strakes create a strong vortex that helps reduce the negative impact of tire squirt on the underbody of the C8.
- On a Z06 with our Dive Planes, Splitter, Rear Diffuser, V1X Rear Wing and Ducktail the guide strakes increase total downforce by 2.8% with no impact to drag.
- They substantially shift the aero balance forward. From 34.6% front (without guide strakes) to 39.0% front (with guide strakes). This increases front grip, or total downforce when matched with increased wing angle.

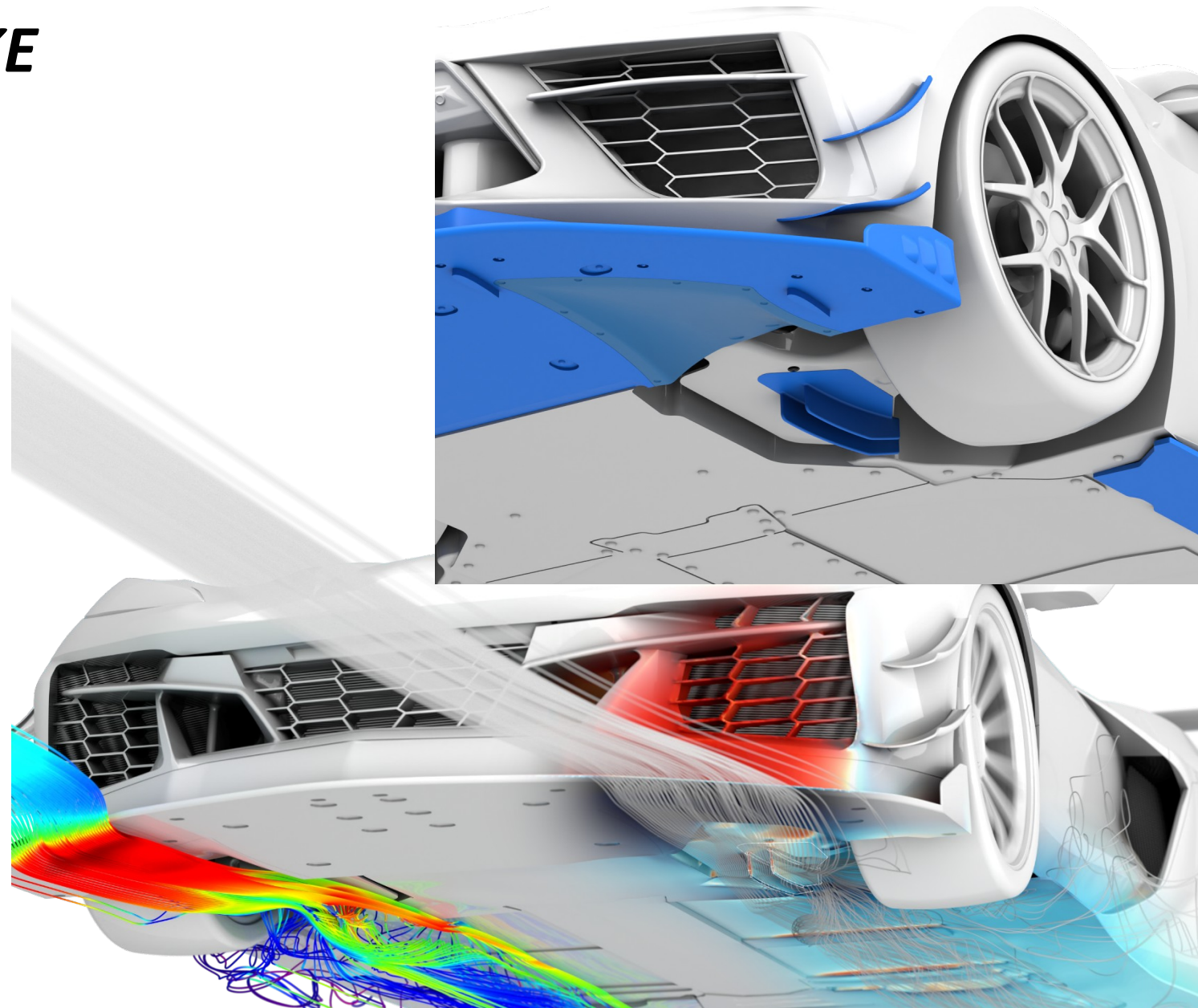

SUMMARY

- The Verus Engineering Ventus Packages for the C8 Stingray/Z51 platform are designed to decrease lap times utilizing well developed and functional aerodynamic components.
- These packages are designed to fit like OEM and increase the factory performance all while keeping the factory warranty.
- The components increase vehicle performance.
- The R&D of the packages was done using cutting edge technology in CFD, knowledge gained through wind tunnel testing, track testing with professional driver, and proven designs from past work.
- The individual components can be installed without the full package, though to ensure a safe balance, we recommend the packages.



QUALITY OF CAD MODEL

- The CAD model is a crucial aspect of accuracy.
- Bad inputs result in bad outputs.
- The CFD simulation is only as good as the geometry and setup of the CFD analysis.
- The C8 was scanned in house and a 3D CAD model was created from this scan.
- The image to the right shows the overlay of the CAD model (gray) and the scan (blue).
- The surfaces are less than 1mm off from the actual scan model in the “worst” locations, with most of the car being less than this.
- Through ducts and front radiator ducting were modeled for improved analysis accuracy.

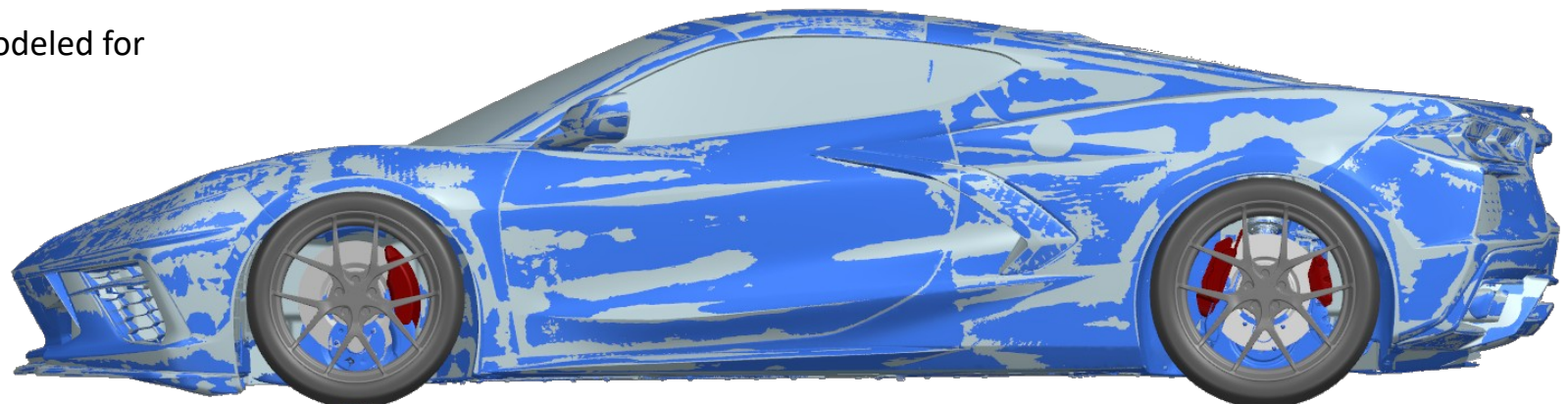

THE SCIENCE

The development was done using OpenFOAM v2306 which is a finite volume CFD software. The solver was SIMPLE and the turbulence model was K-Omega SST using standard wall conditions. We use standard automotive arrangement when setting up boundary conditions and running a full-car. Most of the cases simulated used a slight yawed airflow of 0.5 degrees. This yawed airflow is to ensure we are not analyzing a condition the car will almost never see which is perfectly straight airflow down the length of the car. Other ride heights and yaw rates were also used to simulate cornering.

The use of porous flow was used for all the cooling stacks on the car. The darcy-forchheimer values used were based on past work of similar radiators/heat exchangers. All five coolers in the front were used for the porous flow.

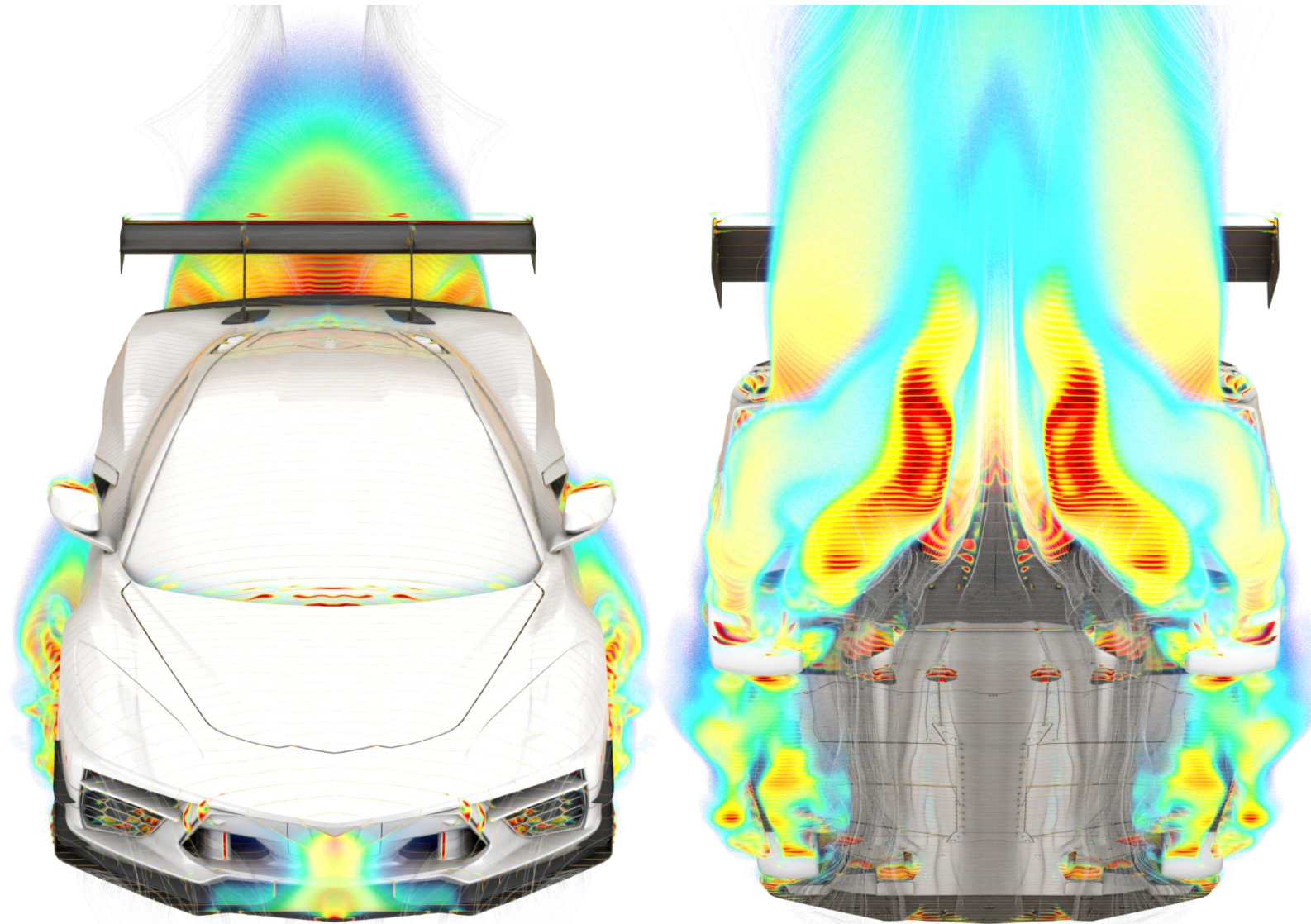

DEFINITIONS

1. **Coefficient of Pressure (Cp)** = This is a dimensionless number which describes relative pressure to atmospheric pressure. A Cp of 0 equates to atmospheric pressure while a number below 0 represents low pressure and a number above 0 represents high pressure.
2. **CpX** = This is a dimensionless number which describes Cp normal to the x-direction. This helps us visualize locations which create drag. Red represents locations which are creating drag, while blue represents locations where thrust is created.
3. **CpZ** = This is a dimensionless number which describes Cp normal to the z-direction. This helps us visualize location which create downforce or lift. Red represents locations which are creating lift, while blue represents locations where downforce is created.
4. **Total Pressure Coefficient (CpT)** = This is a dimensionless number which describes total energy of the airstream. It is the sum of static pressure and dynamic pressure.
5. **Wall Shear** = This is a force per unit area due to fluid friction on the wall. This is used to visualize areas of separation and rapid changes on the surface.
6. **LIC Plot** = Line integral convolution (LIC) is used to visualize “oil” flow on the surface. It is a great way to correlate to flow vis testing and to study the flow on the surface of the vehicle.
7. **Streamline** = These are fluid tracers which are used to visualize where the air is going or coming from. These are normally colored as velocity where red is high-velocity and blue is low-velocity.
8. **Points** = One point is considered 0.001 of a coefficient. This is used in coefficient of drag (Cd) and coefficient of lift (Cl).